

M SERIES PUMPS

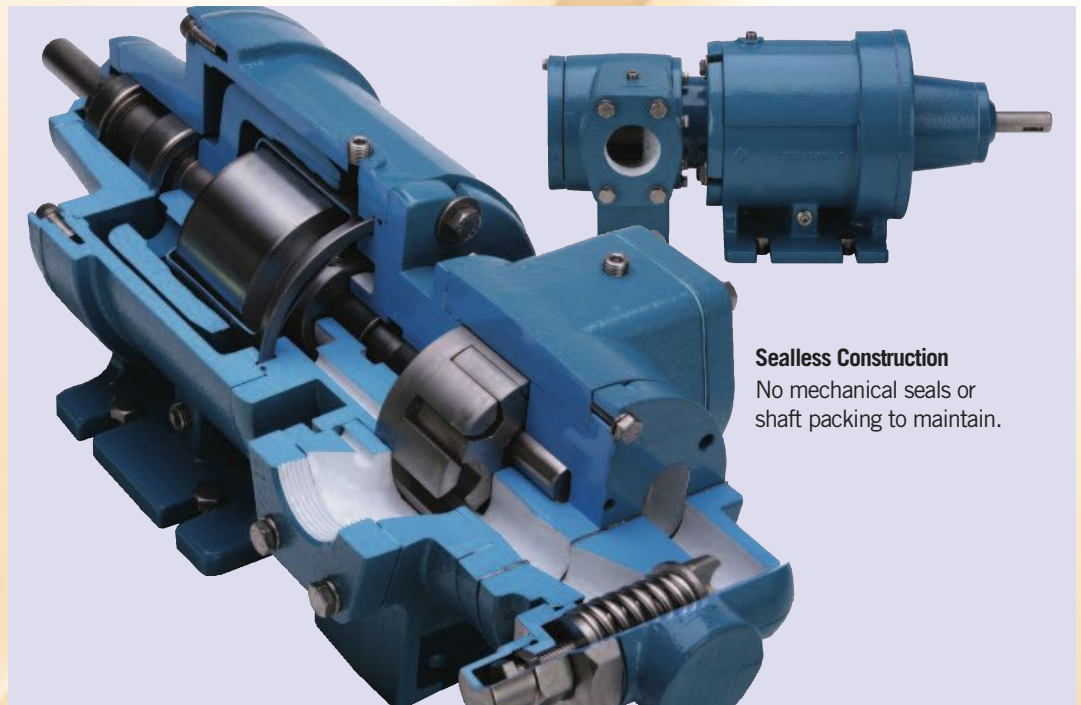

Sealless Construction

No mechanical seals or shaft packing to maintain.

Tuthill's **M Series** magnetic coupled pumps feature a robust design to better withstand the unexpected.

Process upsets and cold starts can result in decoupling and permanent magnet damage that results in costly repairs and unplanned downtime. Using generously sized high temperature magnets can often prevent this situation. That is what Tuthill delivers in the M series magnetically coupled sealless process pumps. With more robust components and superior engineering, these pumps are much less likely to decouple in upset, cold or high viscosity situations. Even in the event of decoupling or run dry, our high temperature magnets are more likely to survive than standard low temperature magnets found in other pumps. Invest in a better pump to avoid those costly magnetic drive pump repairs.



Applications

Difficult to seal liquids such as:
Isocyanate, Styrene,
Sodium Hydroxide

Hazardous liquids such as:
Nitrocellulose

Liquids carrying toxic vapors,
solvents, etc.

Suitable for working
environments where
no leakage can be tolerated

Flow Capacities	.5 to 80 GPM (.11 to 18.2 m ³ /hr)
Pressure	Up to 500 psi (see model chart)
Viscosity	up to 75,000 ssu (16,500 centistokes)
Temperature	300°F (149°C) standard construction 500 °F (260°C) high temperature construction

 **Tuthill**
Engineered Solutions

MASTER DISTRIBUIDOR

M SERIES PUMPS

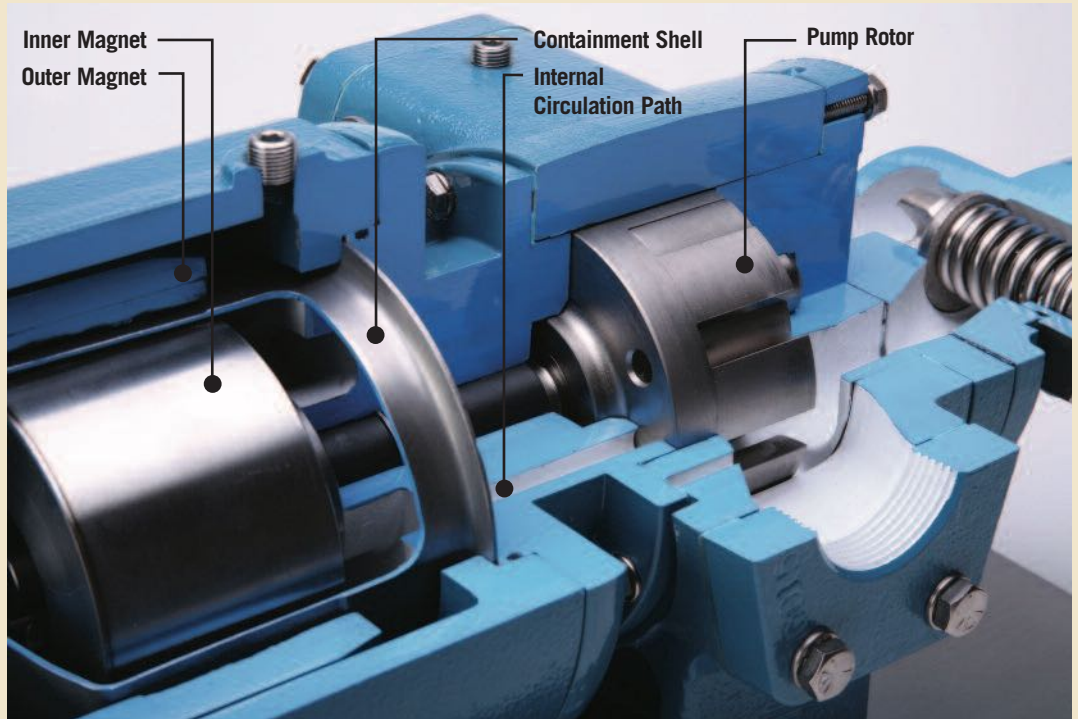

Pump Size	Max GPM	Max m ³ /hr	Max PSI	Construction	Mounting	Port Size	Ports	Magnet Strength Ft-lbs
ML0I	1.8	0.4	500	Iron	Close-coupled	.5" NPT	Opposite	8.5
ML1I	3.2	0.7	500	Iron	Close-coupled	.5" NPT	Opposite	8.5
ML2I	6.2	1.4	500	Iron	Close-coupled	1" NPT	Opposite	8.5
MC2I	9	2.0	100	Iron	Close-coupled	1" NPT	Top	18
MC3I	18	4.1	100	Iron	Close-coupled	1.25" NPT	Top	18
MC4I	36	8.2	100	Iron	Close-coupled	1.5" NPT	Top	18
MC5I	62	14.1	100	Iron	Close-coupled	1.5" NPT	Top	90
MC6I	84	19.1	100	Iron	Close-coupled	2" NPT	Top	90
MG015I	15	3.4	200	Iron	Base mounted	1.5" NPT/BSP	Opposite	18
MG030I	30	6.8	200	Iron	Base mounted	1.5" NPT/BSP	Opposite	18
MG080I	80	18.2	200	Iron	Base mounted	2" 125# ANSI/ISO	Opposite	90
MG015S	12	2.7	150	Stainless	Base mounted	1.5" NPT/BSP	Opposite	18
MG030S	22	5.0	150	Stainless	Base mounted	1.5" NPT/BSP	Opposite	18
MG080S	56	12.7	150	Stainless	Base mounted	2" 150# ANSI/ISO	Opposite	90

Drive Arrangements:

Direct Drive Speeds Available to 1750 RPM
 Compact close-coupled arrangement for ML and MC models
 Gear reduced arrangements available for the MG models

Materials of Construction:

Cast Iron or Stainless Steel Wetted Parts (See model chart)
 Stainless Steel Inner Magnet Assembly and Containment Shell
 Samarium Cobalt High Temperature Rare Earth Magnets
 Carbon Bushings
 PTFE Encapsulated Viton O-Rings

Features:

Generously Sized Magnetic Couplings (Helps Avoid Upset Condition Decoupling)
 High Temperature Rare Earth Magnets Supplied As Standard (Better Withstands Temperature Spikes Seen in Upset Conditions)
 Patented Magnet Area Cooling Path for Effective Heat Dissipation
 Thrust Control for Maximum Life and Reliability
 Skid Rings to Prevent Containment Shell Damage

Options: Relief Valves, High Temperature Pump Construction to 500 °F (260°C), Optional O-Ring Materials



Engineered Solutions

