

# **Itahydraulic**

**Power Tecnology**

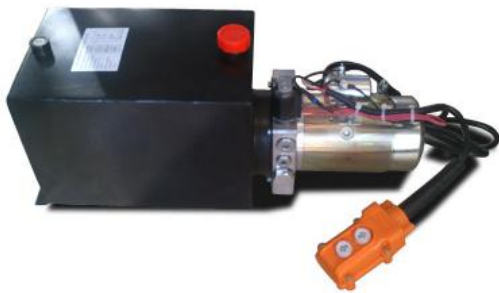

*Hydraulic Power Units*



**Description**

Equiped with a high pressure gear pump,a DC motor, a multifunctional manifold, valves and a tank,ect.This power unit has a power up gravity down circuit. Start the motor to lift the machine and the lowering movement is activated by the solenoid valve with the lowering speed controlled by the pressure compensated flow control valve.

Products of this series are widely used in the industry of logistic devices such as automotive, garden machinery, ect.

**Model Specifications**

Motor Volt	Motor power	Rated Speed	Displacement	System pressure	Tank Capacity	L(mm)
12VDC	1.5KW	2500RPM	2.1mL/r	20MPa	12L	559

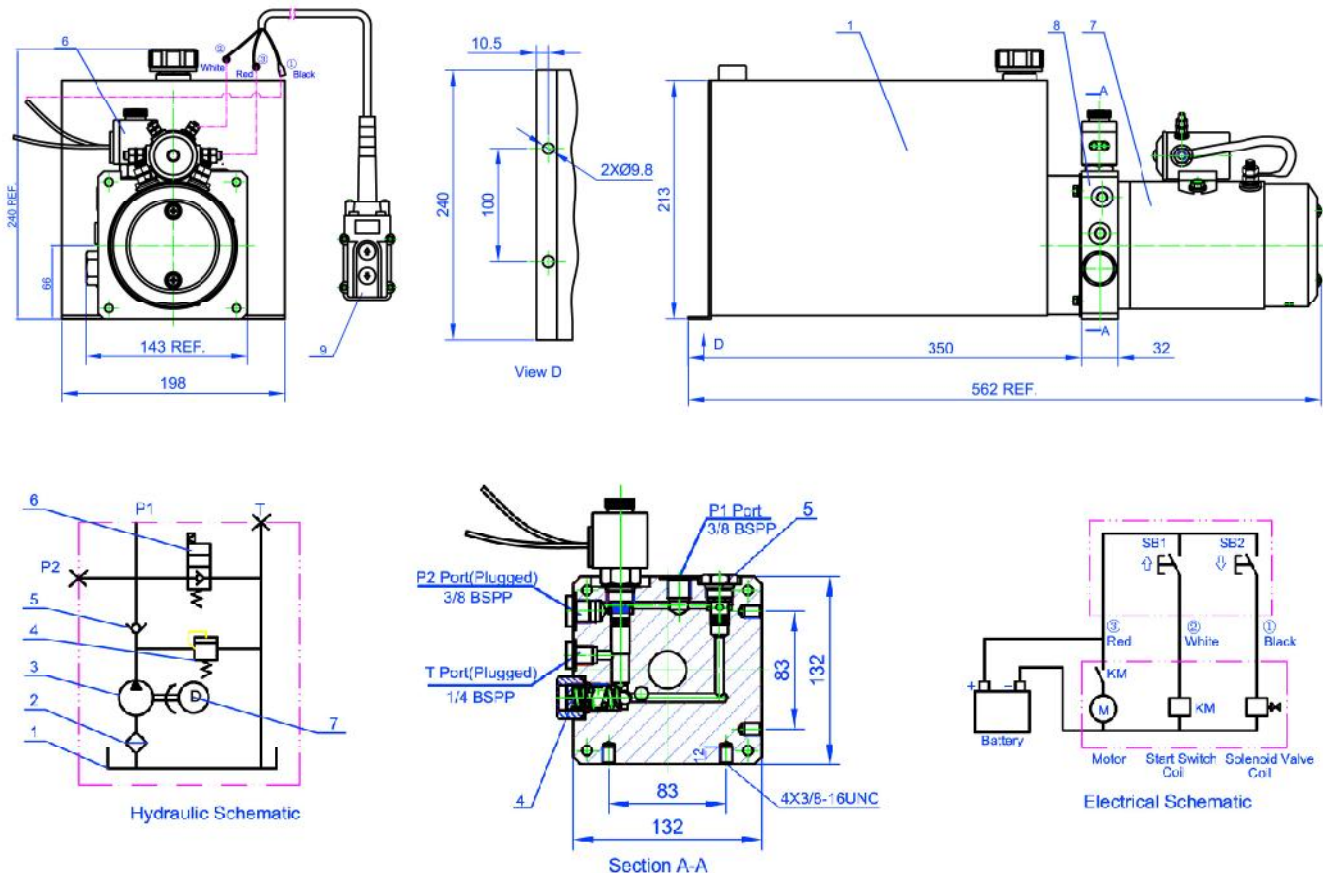



**Description**

Equiped with a high pressure gear pump,a DC motor, a multifunctional manifold, valves and a tank,ect.This power unit has a power up gravity down circuit. Start the motor to lift the machine and the lowing movement is activated by the solenoid valve with the lowering speed controlled by the pressure compensated flow control valve.

Products of this series are widely used in the industry of logistic devices such as automotive, garden machinery, ect.

**Model Specifications**

Motor Volt	Motor power	Rated Speed	Displacement	System pressure	Tank Capacity	L(mm)
24VDC	2.0KW	2500RPM	2.5mL/r	20MPa	12L	559

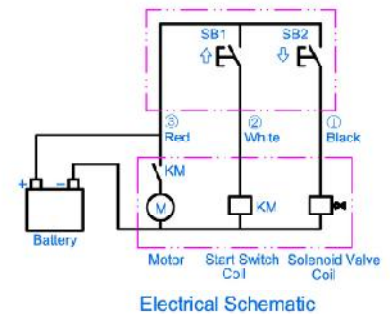
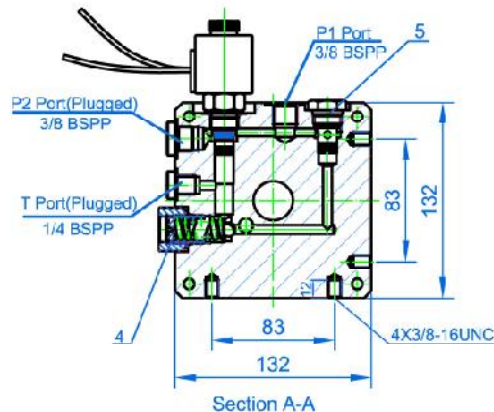
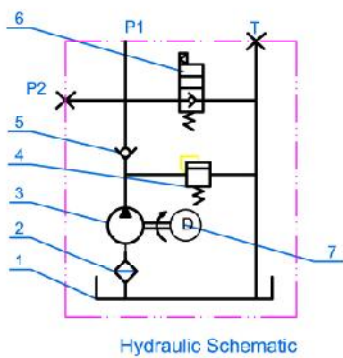
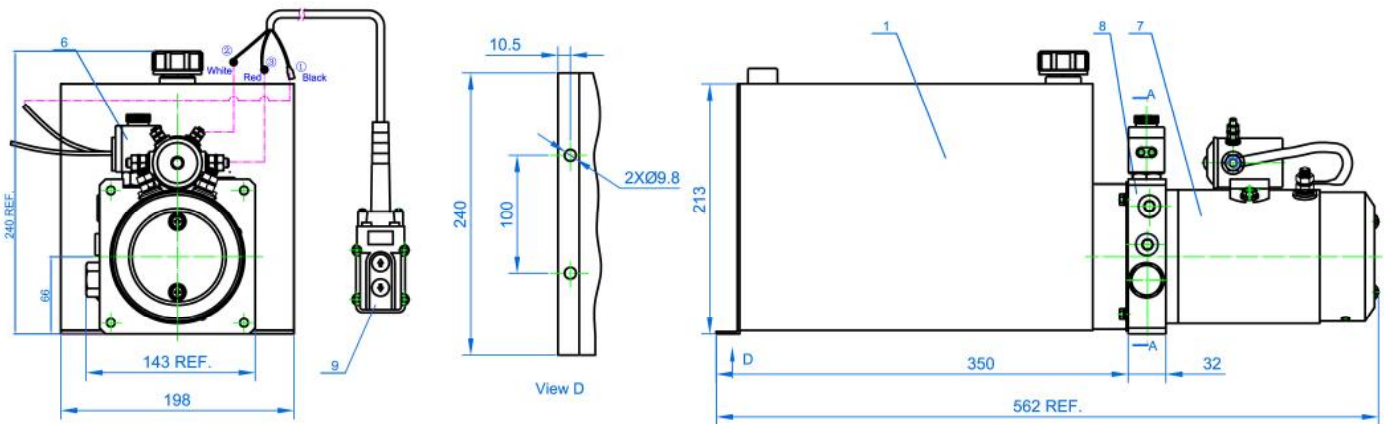



**Description**

Equipped with the zero leakage double-check solenoid valves, this power unit fulfils the complete separation of the two independent circuits, which are respectively for the main platform and subordinate platform of the double scissors lift. By increasing the number of the solenoid valves, it is easy to get more independent circuits, which are used to control the corresponding cylinders.

**Model Specifications**

Motor Volt	Motor power	Rated Speed	Displacement	System pressure	Tank Capacity
220VAC	2.2KW	1450rpm	2.7mL/r	22MPa	8L

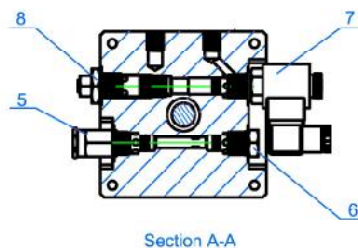
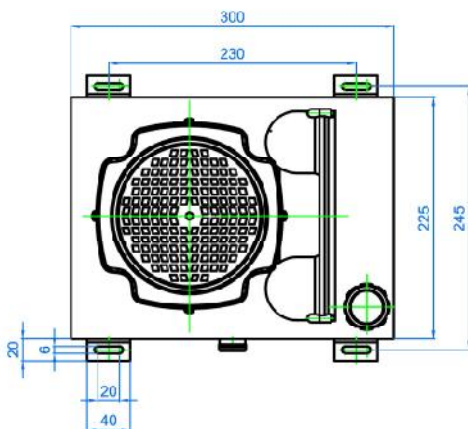
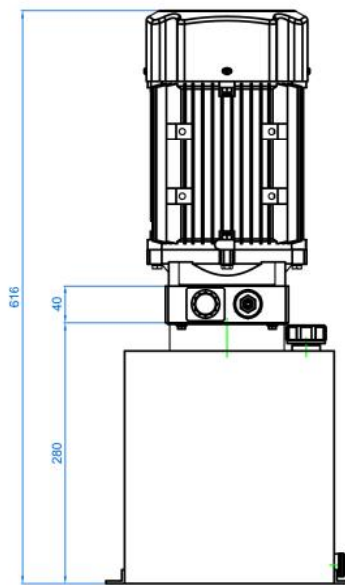
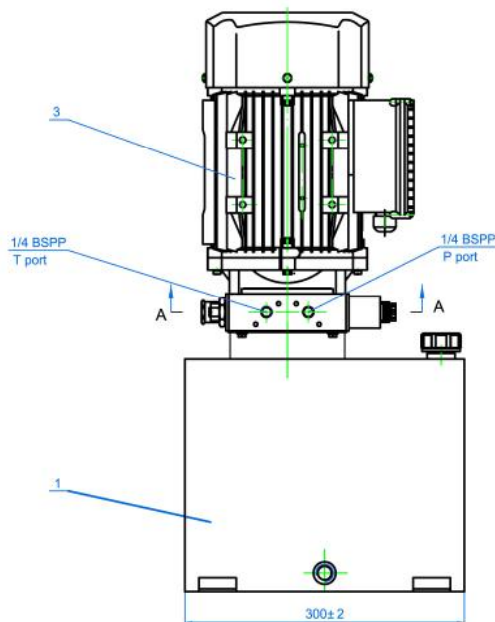

Section A-A

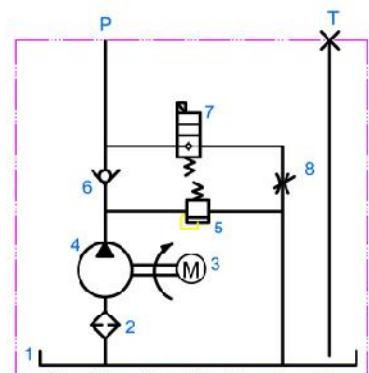

Hydraulic Schematic



**Description**

Equipped with the zero leakage double-check solenoid valves, this power unit fulfils the complete separation of the two independent circuits, which are respectively for the main platform and subordinate platform of the double scissors lift. By increasing the number of the solenoid valves, it is easy to get more independent circuits, which are used to control the corresponding cylinders.

**Model Specifications**

Motor Volt	Motor power	Rated Speed	Displacement	System pressure	Tank Capacity
380VAC	2.2KW	1450rpm	2.7mL/r	16MPa	16L

