



MARK-4[™]

NEMA 4/7/9, shown with standard plastic weight



GP-4[™]

NEMA 4, shown with standard plastic weight

FEATURES AND BENEFITS

Silos up to 100 ft (30.5 m)

- Large range of silo heights can be accommodated

1cm (0.39 inches) Resolution

- Accurate readings

Isolated 4-20 mA Output with Adjustable Span (Reversible)

- No loop isolator is required when connecting to a PLC or DCS

RS-485 Communication

- MODBUS protocol

Remote Display Programmer with Keypad

- 4-line x 20-character backlit LCD display
- Programmable sensor names and ranges
- Enable/Disable network addresses

DESCRIPTION The GP-4[™] and Mark-4[™] Yo-Yo[™] sensors are designed to provide accurate, reliable inventory management information for tanks and silos.

The GP-4 is housed in a NEMA 4 enclosure. The Mark-4 Yo-Yo sensor is housed in a NEMA 4/7/9 enclosure. The Bindicator[®] remote display/programmer can request readings, monitor up to 99 GP-4 and Mark-4 sensors, and program silo parameters. The display/programmer is used to configure a single sensor or a whole system. An adjustable autotimer allows the user to set automatic measurement cycles ranging from 2 minutes to 1 week. While in operating mode, the display will show the sensor address, sensor name, measurement in the specified units, percentage, display mode and the status of the current device. The display can be used with GP-4 Display/Programmer or Bindicator ORB[™].

HOW TO ORDER

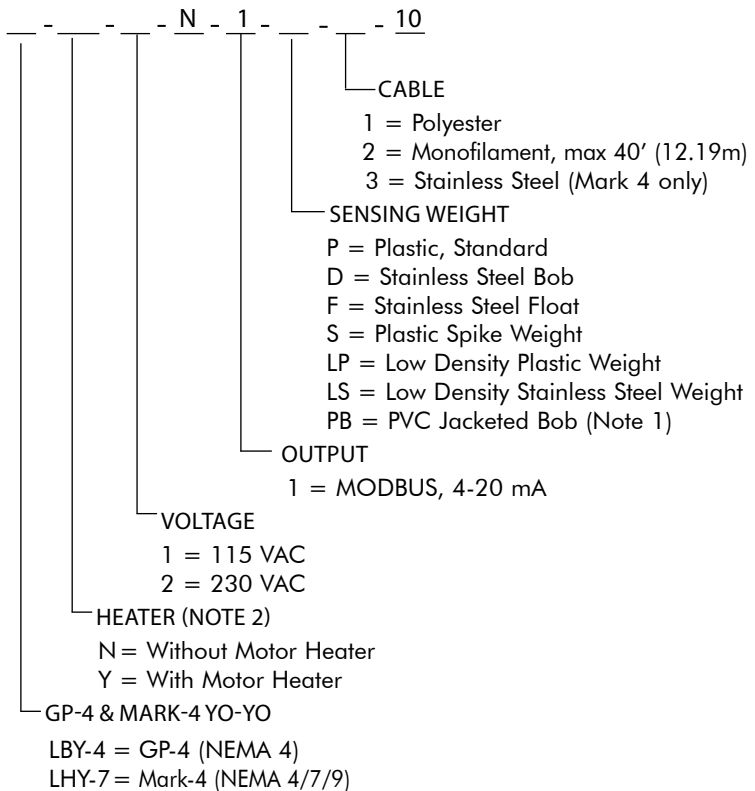

Note 1: Specify monofilament cable.

Note 2: For operation below 32° F (0° C).

SENSOR WEIGHT OPTIONS



P = Plastic, Standard



S = Plastic, Spike Weight



D = SS Bob

SPECIFICATIONS

FUNCTIONAL	MARK-4/GP-4 YO-YO
Operating Power	115 VAC or 230 VAC
Power Consumption	115 VAC, 50/60 Hz, 32 watts (operating), 4 watts (quiescent) (with heater add 10 watts)
Operating Temperature	32° to 120° F (0° to 49° C); with heater -31° to 120° F (-35° to 49° C)
Output	MODBUS, Analog 4-20 mA optically isolated (user sourced) into 600 ohms max
PERFORMANCE	
Repeatability	2 cm (0.8 in)
Measurement Span	Up to 100 ft standard
Automatic Timer	From 2 minutes to 9999 minutes (approx. 1 week)
PHYSICAL	
Mounting	3" NPT
Conduit Entry	GP-4: 2 each 3/4" NPT, Mark-4: 3 each 3/4" NPT
Air Purge Connection	1/4" NPT
Enclosure Material	GP-4: Minlon® frame, low density polyethylene cover Mark-4: Polyester coated cast aluminum
Enclosure Rating	GP-4: NEMA 4 Mark-4: NEMA 4/7/9
Shipping Weight	GP-4: 13 lbs (6 kg) Mark-4: 26 lbs (12kg)
OPTIONS	
	Motor Heater
	YoYo Display
	ORB
APPROVALS	
Mark-4	FM (US) - XP Class I, Division I, Groups C and D; T5, Ta= 60° C DIP Class II, III, Division I, Groups E, F, and G; T5, Ta= 60° C; Type 4 CSA - Class I, Groups C and D; Class II, Groups E, F and G; Class III; Type 5; Type 4 ATEX
GP-4	FM (US) - General Purpose CE

MARK-4™

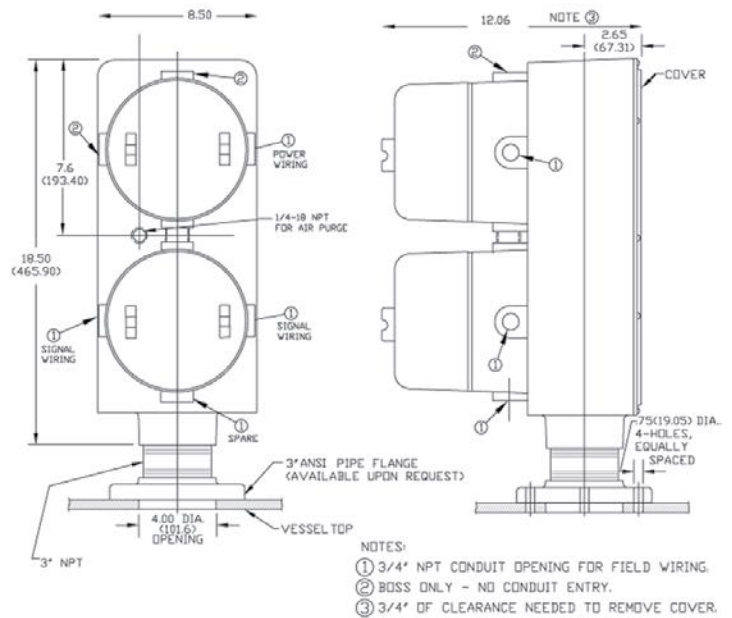

GP-4™

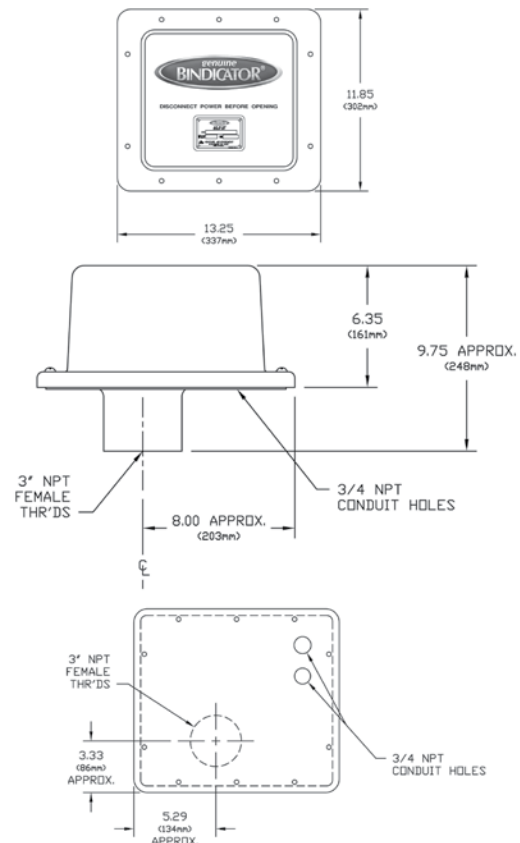

DESCRIPTION The display/programmer allows a user to configure a single sensor or a whole system. An adjustable autotimer allows the user to set automatic measurement cycles ranging from 2 minutes to 1 week. While in operating mode, the display will show the sensor address, sensor name, measurement in the specified units, percentage, display mode and the status of the current device.



FEATURES AND BENEFITS

Remote Sensor Set-up and Configuration

- Allows end user to set-up system from any location

Remote Measurement Request and Display

- Monitors up to 99 sensors from up to 4000 feet

4-line x 20 Character Backlit LCD Display

- Easy to read level, sensor name and status

RS-485 Communication

- MODBUS protocol

Optional Heater

- Keeps system running smoothly in temperatures below -4° F (-20° C)

HOW TO ORDER

LBY-4 - M - 0-10 -

- HEATER (See Note 1)
 - A = Without Heater
 - B = 115 VAC Heater
 - C = 230 VAC Heater
- COMMUNICATIONS
 - M = MODBUS
- DISPLAY / PROGRAMMER

Note 1: For operation below -4° F (-20° C)

SYSTEM CONFIGURATION

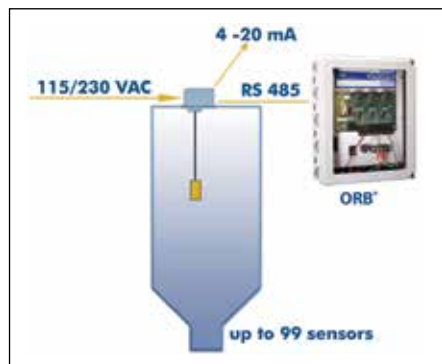
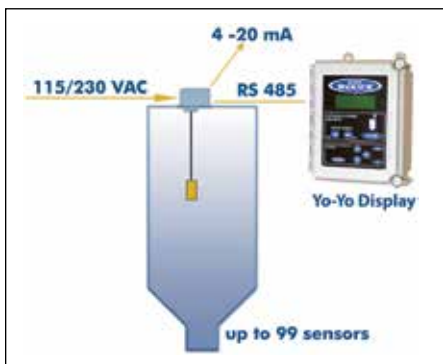

* See ORB Technical Sheet for Specifications.

SPECIFICATIONS

FUNCTIONAL	Display / Programmer
Operating Power	Powered from Yo-Yo sensor (9-24 VDC); With optional heater, 120/240 VAC required
Operating Temperature	-4° F to 158° F (-20° C to 70° C); with optional heater: -40° F to 158° F (-40° C to 70° C)
PHYSICAL	
Communication	RS-485 MODBUS Optional integral modem
Sensors	Up to 99
Display	4 lines by 20 characters Backlit LCD display
Keypad	NEMA 4X soft-touch
Enclosure	NEMA 4X molded fiberglass polyester
PERFORMANCE	
Wiring Requirements	Belden® 9842, 4 wire shielded cable
Wiring Distance	4000' max
Speed	115 Kbps
Protocol	MODBUS
Interface	RS-485
Internal Modem	Optional 56K Modem

DIMENSIONS

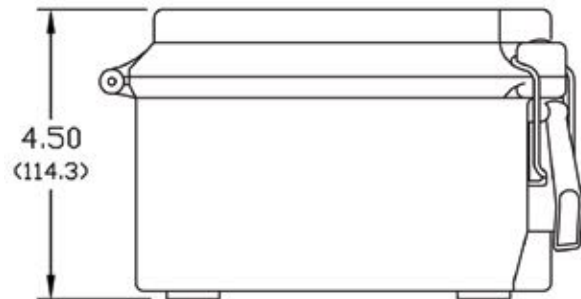
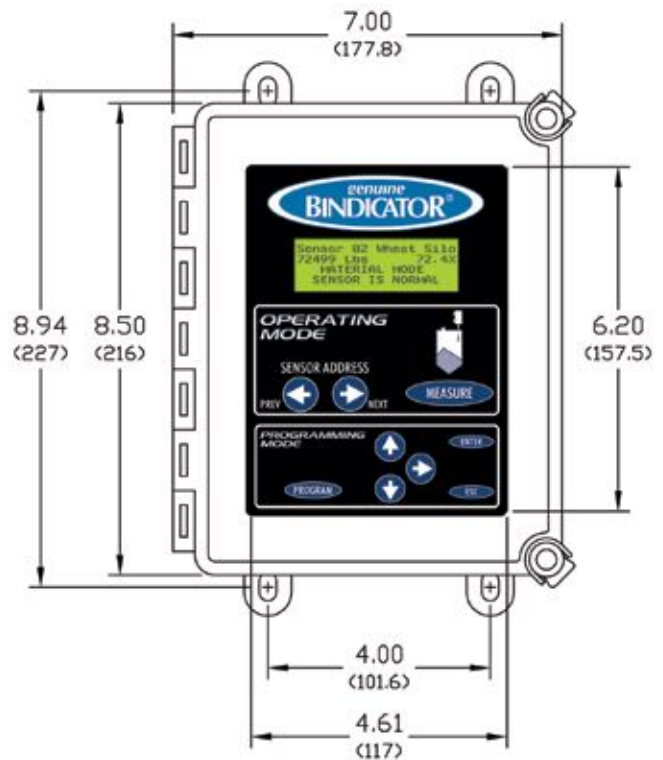

Minlon® is a registered trademark of E.I. Du Pont
Belden® is a registered trademark of Belden Inc.